

Advantage Seal Type 61



The compact, single spring, elastomeric bellows mechanical seal for services:

- Up to 10,000 RPM*
- ID: 7.20 psig (0.5 bar) OD: up to 75 psig (5 bar)
- From - 40°F (-40°C) to 400°F (204°C) *
- Shaft Runout - .05mm per mm/.002 per inch of shaft Dia. FIM max.

** Depending on seal size and material selection*

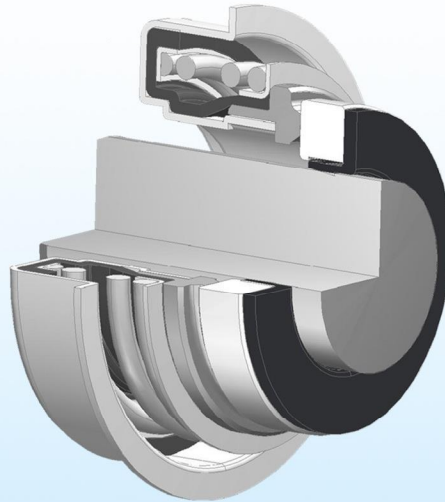

Why choose the Advantage Seal Type 61?



Compact Design

Compact Design

- Allows use in small centrifugal water pumps, deep and shallow well jet pumps, swimming pool pumps, wastewater pumps and submersible pumps



Full Convoluted Bellows

Fully Convoluted Bellows

- Allows maximum flexibility to compensate for shaft movement

Positive Drive

- Torsional movement controlled by dent and groove system to minimize stress on bellows

Single Spring

- Single Coil Spring provides even preloading of the seal face through extreme working conditions

Rotary Mating Ring

- Rotating mating ring provides operation at much higher speeds than rotary head seal design



Rotary Mating ring

Ideal for: Designed for use in small centrifugal water pumps, deep and shallow well jet pumps, swimming pool pumps, wastewater pumps and submersible pumps.

Advantage Seal Type 61 replaces:

- John Crane Type 6A
- Pac-Seal Type 68
- US Seal Type B

Typical Type 61 Dimensions

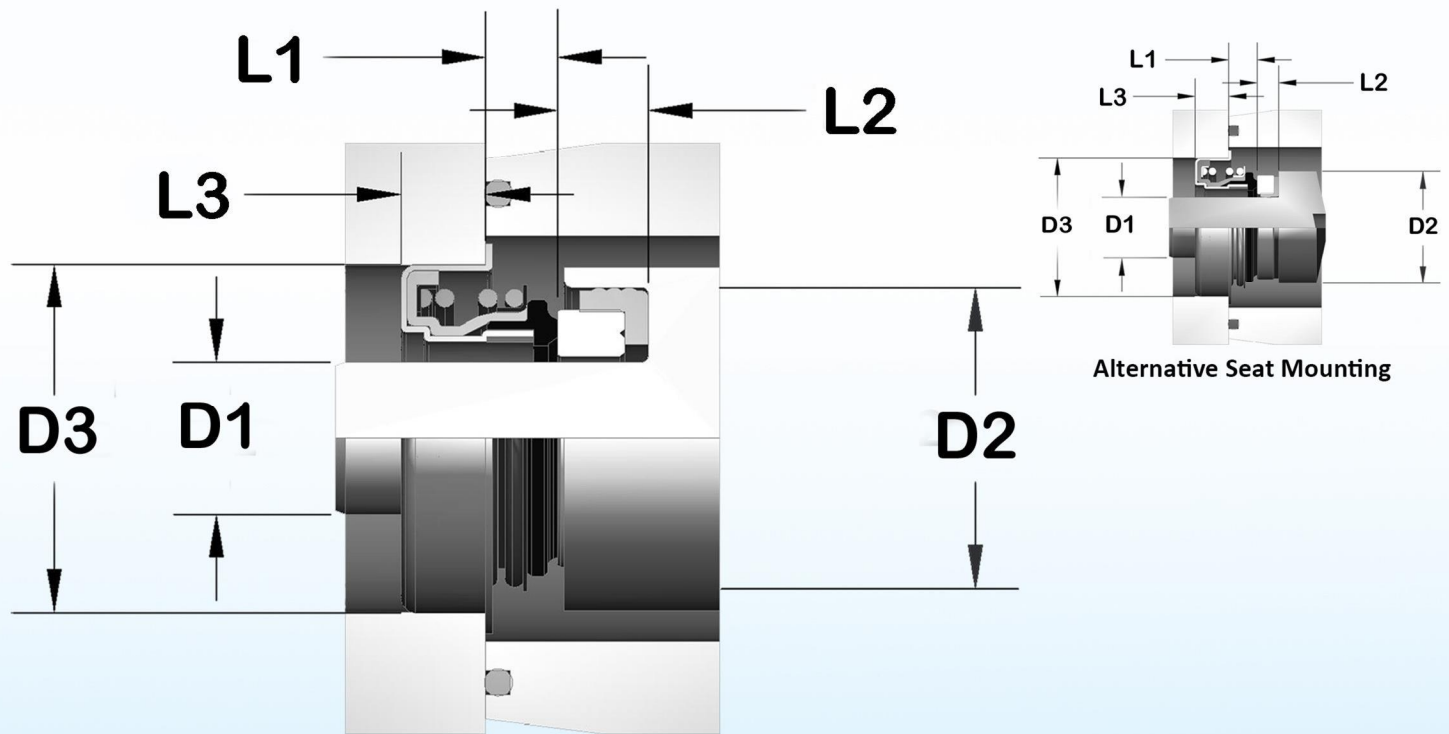

D1		D2		D3		L1		L2		L3	
Inches	Millimeter	Inches	Millimeter	Inches	Millimeter	Inches	Millimeter	Inches	Millimeter	Inches	Millimeter
0.312	7.92			1.125	28.58	0.065	1.65			0.315	8.00
0.375	9.53	0.875	22.23	1.125	28.58	0.065	1.65	0.160	4.06	0.315	8.00
0.375	9.53	0.875	22.23	1.125	28.58	0.065	1.65	0.240	6.10	0.315	8.00
0.375	9.53	0.875	22.23	1.125	28.58	0.065	1.65	0.281	7.14	0.315	8.00
0.375	9.53	1.000	25.40	1.125	28.58	0.065	1.65	0.205	5.21	0.315	8.00
0.500	12.70	1.000	25.40	1.125	28.58	0.187	4.75	0.312	7.92	0.375	9.53
0.500	12.70	1.000	25.40	1.125	28.58	0.187	4.75	0.250	6.35	0.375	9.53
0.500	12.70	1.000	25.40	1.125	28.58	0.187	4.75	0.218	5.54	0.375	9.53
0.500	12.70	1.000	25.40	1.125	28.58	0.187	4.75	0.290	7.37	0.375	9.53
0.625	15.88	1.250	31.75	1.437	36.50	0.265	6.73	0.406	10.31	0.350	8.89
0.625	15.88	1.375	34.93	1.437	36.50	0.265	6.73	0.375	9.53	0.350	8.89
0.625	15.88	1.375	34.93	1.437	36.50	0.265	6.73	0.181	4.60	0.350	8.89
0.625	15.88	1.187	30.15	1.437	36.50	0.265	6.73	0.343	8.71	0.350	8.89
0.625	15.88	1.375	34.93	1.437	36.50	0.265	6.73	0.266	6.76	0.350	8.89
0.625	15.88	1.078	27.38	1.437	36.50	0.265	6.73	0.210	5.33	0.350	8.89
0.625	15.88	1.187	30.15	1.437	36.50	0.265	6.73	0.281	7.14	0.350	8.89
0.625	15.88	1.250	31.75	1.437	36.50	0.265	6.73	0.375	9.53	0.350	8.89
0.625	15.88	1.093	27.76	1.437	36.50	0.265	6.73	0.218	5.54	0.350	8.89
0.625	15.88	1.312	33.32	1.437	36.50	0.265	6.73	0.250	6.35	0.350	8.89
0.625	15.88	1.250	31.75	1.437	36.50	0.265	6.73	0.281	7.14	0.350	8.89
0.750	19.05	1.375	34.93	1.575	40.01	0.265	6.73	0.406	10.31	0.350	8.89
0.750	19.05	1.375	34.93	1.575	40.01	0.265	6.73	0.375	9.53	0.350	8.89
1.000	25.40	1.625	41.28	1.812	46.02	0.312	7.92	0.437	11.10	0.400	10.16

Tolerances and Finishes

- Equipment Shaft ± 0.002 (0.05mm)
- Seat Bore ± 0.002 (0.05mm)
- Maximum End-Play 0.005 (0.13mm)
- Shaft / Sleeve surface finish 35 Ra to 105 Ra